



POWER CARVING UNIT ANGLE GRINDER

INSTRUCTION MANUAL

PWC.SA.600.00

PWC.SA.600.40



UK
CA



Double Insulation used throughout, no provision for earthing.

Fig. B

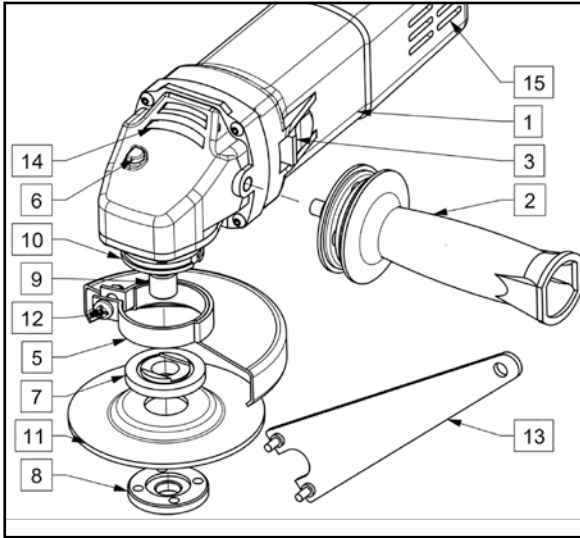

Fig. A

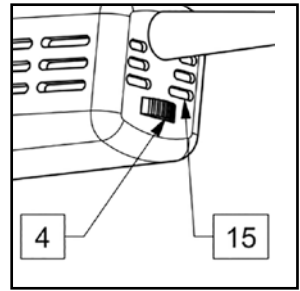

Fig. C

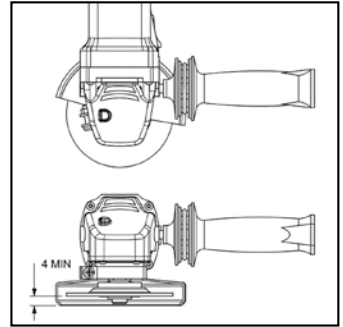

Fig. E

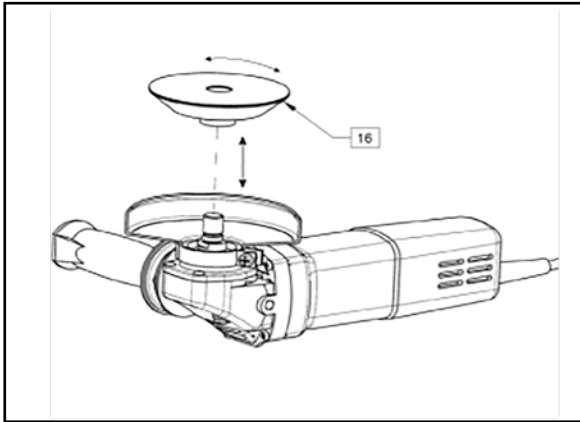
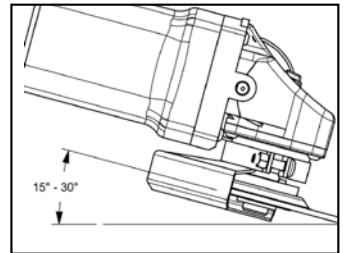

Fig. D



1	Angle Grinder Body	6	Spindle Lock Button	11	Grinding Disc
2	Auxiliary Handle	7	Backing Flange	12	Guard Clamping Screw
3	On/Off Switch	8	Locking Nut	13	Pin Spanner
4	Speed Setting Dial	9	Spindle	14	Front Vents
5	Metal Guard	10	Grinder Collar	15	Rear Vents
16	Sanding Pad				

GENERAL POWER TOOL SAFETY WARNINGS



Failure to follow all instructions listed below, may result in electric shock, fire and/or personal injury.

SAVE ALL WARNINGS AND INSTRUCTIONS FOR FUTURE REFERENCE.

The term "power tool" in the warnings refers to your mains-operated (corded) power tool or battery-operated (cordless) power tool.

1) WORK AREA SAFETY

- Keep work area well ventilated, clean and well lit.** Cluttered or dark areas invite accidents.
- Do not operate power tools in explosive atmospheres, such as in the presence of flammable liquids, gases or dust.** Power tools create sparks which may ignite the dust or fumes.
- Keep children and bystanders away while operating a power tool.** Distractions can cause you to lose control.

2) ELECTRICAL SAFETY

- Power tool plugs must match the outlet.** Never modify the plug in any way. Do not use any adapter plugs with earthed (grounded) power tools. Unmodified plugs and matching outlets will reduce risk of electric shock.
- Avoid body contact with earthed or grounded surfaces, such as pipes, radiators, ranges and refrigerators.** There is an increased risk of electric shock if your body is earthed or grounded.
- Do not expose power tools to rain or wet conditions. Water entering a power tool will increase the risk of electric shock.**
- Do not abuse the cord. Never use the cord for carrying, pulling, or unplugging the power tool. Keep cord away from heat, oil, sharp edges or moving parts.** Damaged or entangled cords increase the risk of electric shock.
- When operating a power tool outdoors, use an extension cord suitable for outdoor use.** Use of a cord suitable for outdoor use reduces the risk of electric shock.

- If operating a power tool in a damp location is unavoidable, use a residual current device (RCD) protected supply.** Use of an RCD reduces the risk of electric shock.

3) PERSONAL SAFETY

- Stay alert, watch what you are doing and use common sense when operating a power tool. Do not use a power tool while you are tired or under the influence of drugs, alcohol or medication.** A moment of inattention while operating power tools may result in serious personal injury.
- Use personal protective equipment. Always wear eye protection.** Protective equipment such as dust mask, non-skid safety shoes, hard hat or hearing protection used for appropriate conditions will reduce personal injuries.
- Prevent unintentional starting. Ensure the switch is in the off-position before connecting to a power source and/or battery pack, picking up or carrying the tool.** Carrying power tools with your finger on the switch or energizing power tools that have the switch on invites accidents.
- Remove any adjusting key or wrench before turning the power tool on.** A wrench or a key left attached to a rotating part of the power tool may result in personal injury.
- Do not overreach. Keep proper footing and balance at all times.** This enables better control of the power tool in unexpected situations.
- Dress properly. Do not wear loose clothing or jewellery. Keep your hair, clothing and gloves away from moving parts.** Loose clothes, jewellery or long hair can be caught in moving parts.
- If devices are provided for the connection of dust extraction and collection facilities, ensure these are connected and properly used.** Use of dust collection can reduce dust-related hazards.
- Do not let familiarity gained from frequent use of tools allow you to become complacent and ignore tool safety.** A careless action can cause severe injuries within a fraction of a second.

4) POWER TOOL USE AND CARE

- Do not force the power tool. Use the correct tool for your application.** The correct power tool will do the job better and safer at the rate for which it was designed.
- Do not use the tool if the switch does not turn it on and off.** Any power tool that cannot be controlled with the switch is dangerous and must be repaired.

- c. **Disconnect the plug from the power source and/or the battery pack from the power tool before making any adjustments, changing accessories, or storing power tools.** Such preventative safety measures reduce the risk of starting the power tool accidentally.
 - d. **Store idle power tools out of the reach of children and do not allow persons unfamiliar with the power tool or these instructions to operate the power tool.** Power tools are dangerous in the hands of untrained users.
 - e. **Maintain power tools and accessories. Check for misalignment or binding of moving parts, breakage of parts and any other condition that may affect the power tools operation. If damaged, have the power tool repaired before use.** Many accidents are caused by poorly maintained power tools.
 - f. **Keep cutting tools sharp and clean.** Properly maintained cutting tools with sharp edges are less likely to bind and are easier to control.
 - g. **Use the power tool, accessories and tool bits etc. in accordance with these instructions, taking into account the working conditions and the work to be performed.** Use of the power tool for operations different from those intended could result in a hazardous situation.
 - h. **Keep handles and grasping surfaces dry, clean and free from oil and grease.** Slippery handles and grasping surfaces do not allow for safe handling and control of the tool in unexpected situations.
- c. **Do not use accessories which are not specifically designed and recommended by the tool manufacturer.** Just because the accessory can be attached to your power tool, it does not assure safe operation.
 - d. **The rated speed of the accessory must be at least equal to the maximum speed marked on the power tool.** Accessories running faster than their rated speed can break and fly apart.
 - e. **The outside diameter and the thickness of your accessory must be within the capacity rating of your power tool.** Incorrectly sized accessories cannot be adequately guarded or controlled.
 - f. **Threaded mounting of accessories must match the grinder spindle thread. For accessories mounted by flanges, the arbour hole of the accessory must fit the locating diameter of the flange.** Accessories that do not match the mounting hardware of the power tool will run out of balance, vibrate excessively and may cause loss of control.
 - g. **Do not use a damaged accessory. Before each use inspect the accessory such as abrasive wheels for chips and cracks, backing pad for cracks, tear or excess wear. If power tool or accessory is dropped, inspect for damage or install undamaged accessory. After inspecting and installing an accessory, position yourself and bystanders away from the plane of the rotating accessory and run the power tool at maximum no-load speed for one minute.** Damaged accessories will normally break apart during this test time.

5) SERVICE

- a. **Have your power tool serviced by a qualified repair person using only identical replacement parts.** This will ensure that the safety of the power tool is maintained.
- h. **Wear personal protective equipment. Depending on application, use face shield, safety goggles or safety glasses. As appropriate, wear dust mask, hearing protectors, gloves and workshop apron capable of stopping small abrasive or workpiece fragments.** The eye protection must be capable of stopping flying debris generated by various operations. The dust mask or respirator must be capable of filtrating particles generated by your operation. Prolonged exposure to high intensity noise may cause hearing loss.



ANGLE GRINDER SAFETY WARNINGS

6) SAFETY WARNINGS COMMON FOR GRINDING AND SANDING OPERATIONS:

- a. **This power tool is intended to function as a grinder or sander. Read all safety warnings, instructions, illustrations and specifications provided with this power tool.** Failure to follow all instructions listed below may result in electric shock, fire and/or serious injury.
- b. **Operations such as wire brushing or cut-off operations are not recommended to be performed with this power tool.** Operations for which the power tool was not designed may create a hazard and cause personal injury.
- i. **Keep bystanders a safe distance away from work area. Anyone entering the work area must wear personal protective equipment.** Fragments of workpiece or of a broken accessory may fly away and cause injury beyond immediate area of operation.
- j. **Hold the power tool by insulated gripping surfaces only, when performing an operation where the cutting accessory may contact hidden wiring or its own cord.** Cutting accessory contacting a "live" wire may make exposed metal parts of the power tool "live" and could give the operator an electric shock.

- k. **Position the cord clear of the spinning accessory.** If you lose control, the cord may be cut or snagged and your hand or arm may be pulled into the spinning accessory.
- l. **Never lay the power tool down until the accessory has come to a complete stop.** The spinning accessory may grab the surface and pull the power tool out of your control.
- m. **Do not run the power tool while carrying it at your side.** Accidental contact with the spinning accessory could snag your clothing, pulling the accessory into your body.
- n. **Regularly clean the power tool's air vents.** The motor's fan will draw the dust inside the housing and excessive accumulation of powdered metal may cause electrical hazards.
- o. **Do not operate the power tool near flammable materials.** Sparks could ignite these materials.
- p. **Do not use accessories that require liquid coolants.** Using water or other liquid coolants may result in electrocution or shock.

7) KICKBACK AND RELATED WARNINGS

Kickback is a sudden reaction to a pinched or snagged rotating wheel, backing pad, brush or any other accessory. Pinching or snagging causes rapid stalling of the rotating accessory which in turn causes the uncontrolled power tool to be forced in the direction opposite of the accessory's rotation at the point of the binding.

For example, if an abrasive wheel is snagged or pinched by the workpiece, the edge of the wheel that is entering into the pinch point can dig into the surface of the material causing the wheel to climb out or kick out. The wheel may either jump toward or away from the operator, depending on direction of the wheel's movement at the point of pinching. Abrasive wheels may also break under these conditions. Kickback is the result of power tool misuse and/or incorrect operating procedures or conditions and can be avoided by taking proper precautions as given below.

- a. **Maintain a firm grip on the power tool and position your body and arm to allow you to resist kickback forces. Always use auxiliary handle, if provided, for maximum control over kickback or torque reaction during start-up.** The operator can control torque reactions or kickback forces, if proper precautions are taken.
- b. **Never place your hand near the rotating accessory.** Accessory may kickback over your hand.
- c. **Do not position your body in the area where power tool will move if kickback occurs.** Kickback will propel the tool in direction opposite to the wheel's movement at the point of snagging.

- d. **Use special care when working corners, sharp edges etc. Avoid bouncing and snagging the accessory.** Corners, sharp edges or bouncing have a tendency to snag the rotating accessory and cause loss of control or kickback.
- e. **Do not attach a saw chain wood carving blade or toothed saw blade.** Such blades create frequent kickback and loss of control.
- f. **Do not attach reinforced abrasive cut-off wheel.** Such tools can break-off and cause injuries.

8) SAFETY WARNINGS SPECIFIC FOR GRINDING OPERATIONS:

- a. **Use only wheel types that are recommended for your power tool and the specific guard designed for the selected wheel.** Wheels for which the power tool was not designed cannot be adequately guarded and are unsafe.
- b. **The grinding surface of centre depressed wheels must be mounted below the plane of the guard lip.** An improperly mounted wheel that projects through the plane of the guard lip cannot be adequately protected.
- c. **The guard must be securely attached to the power tool and positioned for maximum safety, so the least amount of wheel is exposed towards the operator.** The guard helps to protect the operator from broken wheel fragments, accidental contact with wheel and sparks that could ignite clothing.
- d. **Wheels must be used only for recommended applications. For example: do not grind with the side of cut-off wheel.** Abrasive cut-off wheels are intended for peripheral grinding, side forces applied to these wheels may cause them to shatter.
- e. **Always use undamaged wheel flanges that are of correct size and shape for your selected wheel.** Proper wheel flanges support the wheel thus reducing the possibility of wheel breakage. Flanges for cut-off wheels may be different from grinding wheel flanges.
- f. **Do not use worn down wheels from larger power tools.** Wheel intended for larger power tool is not suitable for the higher speed of a smaller tool and may burst.

9) ADDITIONAL SAFETY WARNINGS SPECIFIC FOR SANDING OPERATIONS:

- a. **Do not use excessively oversized sanding disc paper.** Follow manufacturers recommendations, when selecting sanding paper. Larger sanding paper extending beyond the sanding pad presents a laceration hazard and may cause snagging, tearing of the disc or kickback.
- b. **Adjust the speed as recommended for sanding applications.** High speed sanding presents laceration and burning hazard.

ADDITIONAL SAFETY WARNINGS



**Wear hearing protection; Wear eye protection;
Wear dust mask; Wear protective gloves.**

- Use suitable detectors to determine if utility lines are hidden in the work area or call the local utility company for assistance.** Contact with electric lines can lead to fire and electric shock. Damaging a gas line can lead to explosion. Penetrating a water line causes property damage or may cause an electric shock.
- Release the On/Off switch and set it to the off position when the power supply is interrupted,** e. g., in case of a power failure or when the mains plug is pulled.
- Do not touch grinding and cutting discs before they have cooled down.** The discs can become very hot while working.
- Secure the workpiece.** A workpiece clamped with clamping devices or in a vice is held more secure than by hand.

PRODUCT DESCRIPTION AND SPECIFICATIONS



Read all safety warnings and all instructions. Failure to follow the warnings and instructions may result in electric shock, fire and/or serious injury.

INTENDED USE

The machine is designed for grinding and sanding applications. The machine is designed and constructed for use with attachments supplied by the manufacturer. The machine can only be used for dry applications without use of water.

UK- Declaration of Conformity

Arbortech declares that the product described in this manual under "Technical Specifications" is manufactured in compliance with EN 60745 standardised documents and following UK regulations:

- Supply of Machinery (Safety) Regulations 2008
- Electromagnetic Compatibility Regulations 2016
- The Restriction of the Use of Certain Hazardous Substances in Electrical and Electronic Equipment Regulations 2012

Technical file at: Arbortech Ltd, 67 Westchester Road, Malaga, WA 6090, Australia

Sven Blinks
General Manager

EC- Declaration of Conformity

Arbortech declares that the product described in this manual under "Technical Specifications" is manufactured in compliance with EN 60745 standardised documents, and in conformity with Machinery Directives 2006/42/EC; 2014/30/EU; 2011/65/EU.

Technical file at: Arbortech PTY LTD | 67 Westchester Road, Malaga, WA 6090

Sven Blinks
General Manager

Voltage	230-240	V
Power Rating	710	W
Frequency	50	Hz
Protection Class	II	II
Rated Speed	2 000 – 11 000	rpm
Tool Max. Diameter	115	mm
Mounting Bore Size	22.2	mm
Mounting Thread Size	M14	-
Weight	2.0	kg
Vibration Emission (k=1.5)	2.6	m/s ²
Sound Pressure Level	$L_{pA} = 89$ $K_{pA} = 3$	dB(A)
Sound Power Level	$L_{wA} = 100$ $K_{wA} = 3$	dB(A)

 **WARNING:** The declared vibration emission level represents the main applications of the tool. However if the tool is used for different applications, with different accessories or insertion tools or is poorly maintained, the vibration emission may differ. This may significantly increase the exposure level over the total working period.

An estimation of the level of exposure to vibration should also take into account the times when the tool is switched off or when it is running but not actually doing the job. This may significantly reduce the exposure level over the total working period. Identify additional safety measures to protect the operator from the effects of vibration.

ASSEMBLY

 **WARNING:** To reduce the risk of serious personal injury, turn the tool off and disconnect from the power source before making any adjustments or removing/installing tools or accessories.

AUXILIARY HANDLE

Screw the handle (2) into one of the side holes on the head of the grinder as shown in Fig. B. Ensure the handle is secure before use.

METAL GUARD

When using a grinding wheel, first install the metal guard (5) over the collar (10) and rotate the guard on the tool so that the closed side of the guard always points toward the operator as shown in Fig. C. Tighten the screw (12) so the guard cannot move out of position.

FLANGES AND WHEELS

Mount the backing flange (7) onto the spindle (9) with the slot orientated so that it interlocks with the spindle. Fit the disc, ensuring it sits correctly onto the flange, then screw on the lock nut (8). Press the spindle lock (6) and tighten the lock nut using the pin spanner (13).

For installation and operation of other Arbortech accessories please refer to their dedicated instructions.

OPERATION

 **WARNING:** Always read the safety instructions and applicable regulations. To reduce the risk of injury, turn the tool off and disconnect from power source before making any adjustments or removing/installing accessories

- a) **The electric motor has been designed for the voltage stated on the label.** Always check the power supply corresponds to the voltage marked on the motor.
- b) **Always wear correct safety clothing, including ear, eye and lung protection.**
- c) **Follow local government safety regulations when working on materials treated with or containing toxic substances.**
- d) **Do not use this tool in wet conditions or in the presence of flammable liquids and gases.**
- e) **Check tool before using.** The grinding disc must be mounted properly and be able to move freely. Test run the power tool with no load prior to use. Do not use damaged, out of centre or vibrating tools.
- f) **Do not exert pressure or strain the machine so heavily that it comes to a standstill.** After heavily straining the power tool, continue to run it at no load for a minute to cool down the accessory.
- g) **Do not touch cutting tools before they have cooled down.** The discs can become very hot while working.

 **WARNING:** Always use two hands to operate this power tool, placing the left hand on the auxiliary handle and the right on the tool body so you can switch the motor on and off at any time. Always use protective gloves while operating this tool.

Ensure an appropriate speed setting is selected for the application from the table below. Support and secure the workpiece to prevent movement and loss of control.

Ensure the machine is running before contacting the work piece. Approach the workpiece with caution to avoid sudden grabbing and gently push against it. Hold the

grinder at an angle of 15°-30° for grinding and 5°-30° for sanding, as shown in Fig. D. Move the tool in the desired direction, keeping contact between the workpiece and the disc.

Accessory	Speed Setting	Application
Grinding Disc	5 – 6	Grinding
Sanding Pad	1 – 3	Sanding wood, metal and other materials. Use lower speed with higher grit sand paper

SWITCHING ON AND OFF

To start the power tool, push the On/Off switch (3) forward. To lock the switch, press it down at the front until it latches. To switch off the tool, release the On/Off switch or, if it is locked, briefly push down the back of the switch and release.

 **WARNING:** The tool includes a restart prevention feature, which prevents uncontrolled restarting after an interruption to the power supply. To resume operation, switch the tool to the off position and start the machine again.

MAINTENANCE

 **WARNING:** Before any adjustment, cleaning or maintenance work on the machine itself, disconnect from the power supply.

Inspect the accessories for damage and maintain them as specified in their user manual. If the guard is broken or parts of the guard become loose and can be detached, replace damaged parts. Do not use the tool without the appropriate guard specified for the intended application.

For your safety and the reliability of this product, all electrical repair and maintenance of the internal parts, other than maintaining accessories and attachments, should be carried out by Arbortech authorised service centres.

CLEANING THE AIR VENTS AND SWITCH

Regularly check to see if any dust or foreign matter has entered the air vents, positioned on the front and back of the motor (14 and 15), or under the On/Off switch. If so, use a soft brush to remove any accumulated dust to clean the air vents and switch. Clean the accessories from dust to prevent build up and avoid incorrect mounting, setup and adjustments.

OPTIONAL ACCESSORIES

To avoid the risk of injuries or damaging your tool, use only Arbortech recommended accessories and attachments. Consult your dealer for availability of optional accessories.



www.arbortechtools.com

ARBORTECH PTY LTD

Address:

67 WESTCHESTER ROAD MALAGA 6090

PERTH WESTERN AUSTRALIA

Tel: 08 9249 1944 Fax: 08 9249 2936

U.S.A. - Tollfree: 866-517-7869

U.S.A Office: 978-466-7945 U.S.A Fax: 866-515-8104

EUROPE: Tel: +49 2724-288301 Fax: +49 2724-205515

Facebook: @arbortechtools

Email: arbortech@arbortech.com.au